

This Is An Original Product From Fulham Co., Inc

Description: 48V, 150W Constant Voltage LED Driver. Universal Input Range of 120 - 277V. One 48V Independent, Constant Voltage Output Channel.

This Driver Will Operate Following LED:

Any LED Module designed to accept constant voltage input of 48V and has a maximum input current of 3.12A.

ELECTRICAL DATA

INPUT VOLTAGE	120~277VAC, 50/60Hz
INPUT CURRENT (MAX)	1.5A @ 120VAC
POWER FACTOR (PF)	> 0.9
THD	<10% @ Full Load
EFFICIENCY	> 90%
DRIVE METHOD	Constant Voltage
OUTPUT CURRENT	3.12A
OUTPUT VOLTAGE	48V
OUTPUT WATTAGE	150W
NUMBER OF OUTPUT CHANNELS	1
RFI/EMI	FCC PART 15A, NON- CONSUMER
SOUND RATING	A
CIRCUIT PROTECTION	SURGE PROTECTION 2KV/6KV
	CURRENT PROTECTION
	OUTPUT SHORT CIRCUIT PROTECTION
	OUTPUT OPEN CIRCUIT PROTECTION
	OUTPUT TO GROUND SHORT PROTECTION
OVER LOAD PROTECTION	
MAX. CASE HOT SPOT TEMPERATURE	80°C
AMBIENT TEMPERATURE RANGE	-40°C to +60°C
SERVICE LIFE	50,000 Hours
APPROVALS/CLASS	cURus, Non Class 2, RoHS, Dry or Damp Locations, Type HL

MECHANICAL DATA

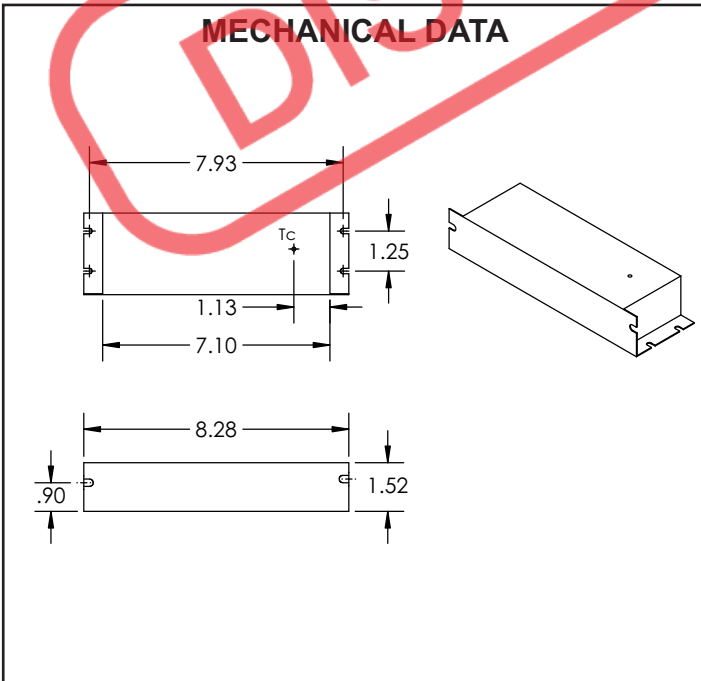

WIRING DIAGRAMS

WIRE	BLACK	WHITE	RED	BLUE		
LENGTH - INCHES	12 ± 1"	12 ± 1"	24 ± 1"	24 ± 1"		

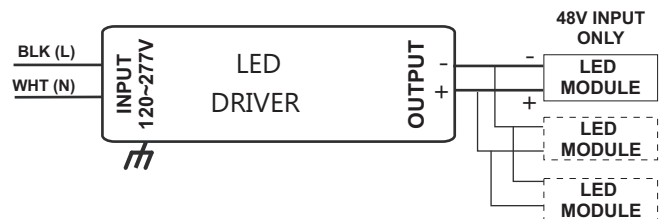

Driver must be grounded.

Fulham extends a limited warranty only to the original purchaser or to the first user for a period of 5 years from the date of manufacture when properly installed and operated under normal conditions of use. For complete terms and conditions, please reference the Fulham product catalog (www.fulham.com)
Due to a program of continuous improvement, Fulham reserves the right to make modifications or variations in design or construction to the equipment described.