

Description:

RaceHorse 230V Series, Electronic Ballasts, Programmed Preheat-Start, Cut-Off Technology, Thermal Protection, End-Of-Life (EOL) Protection, High Power Factor due to Active Power Factor Control (APFC) Technology.

RaceHorse 230V Serie, Elektronische Vorschaltgeräte (EVG), Programmierter Warm-Start, Cut-Off Technologie, Wärmeschutz, Sicherheitsabschaltung bei defekten Lampen, hoher Leistungsfaktor durch APFC- Technologie.

This Ballast Will Operate Following Lamps:

Please refer to Lamp List

Mechanical Data:

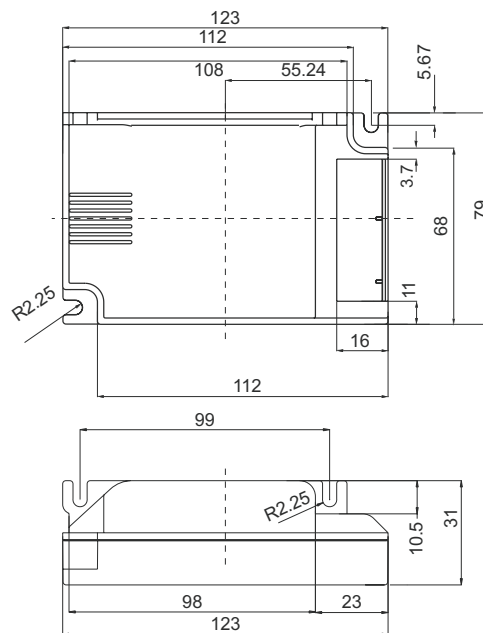
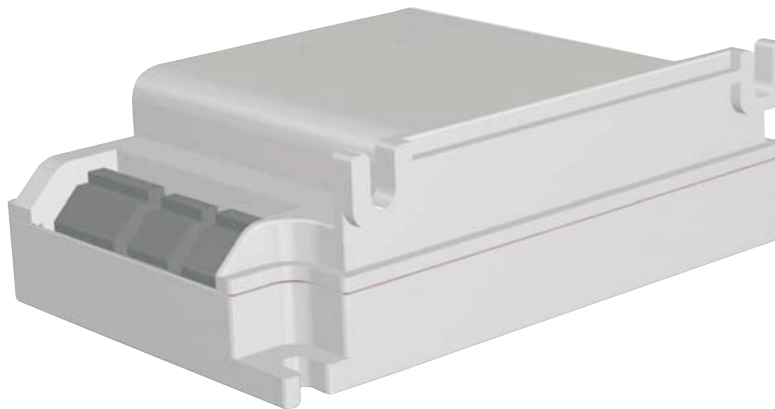

Fulham Company extends limited warranty only to the original purchaser or to the first user for the period of **5 years** from the date of manufacture as indicated by the date code stamped on each product and when properly installed and under normal conditions of use.

DUE TO A PROGRAM OF CONTINUOUS IMPROVEMENT, FULHAM Co., INC RESERVES THE RIGHT TO MAKE ANY VARIATION IN DESIGN OR CONSTRUCTION TO THE EQUIPMENT DESCRIBED.

Fulham Co., Inc. Address: 12705 South Van Ness Ave., Hawthorne, CA 90250 Tel.: 1-323-599-5000 Fax.: 1-323-754-9060 Website: www.fulham.com

2010-0302-1

Fulham Company GmbH Adresse: Karolinenstrasse 18, D-58507 Lüdenscheid, Germany Fon: +49 2351 4327416 Fax: +49 2351 6567349 Handelsregister Iserlohn: HR B 6286

Electrical Data:

Input Voltage [V]	Versorgungsspannung [V]	220 - 240
Power Line Frequency [Hz]	Netzfrequenz [Hz]	50 / 60
Input Voltage Range [V]	Wechsel-/Eingangsspannungsbereich [V]	(-10%) 198 - 264 (+10%)
Maximum Line Current [A]	Max. Leitungsstrom [A]	0.17
Input Wattage (Lamp+Ballast) [W]	Systemleistung (Lampe+EVG) [W]	a) - e): 40, 40
Input Power Factor (PF) [β]	(Eingangs-) LeistungsFaktor [β]	0.98
Line Current Harmonics (THD) [%]	Korrigierte Netzstrom Oberschwingungen [%]	10
In Rush Current [A]/Start-Up Current	Einschaltstrom [A]	< 50
Dimming Interface	1 bis 10 V Schnittstelle	1V to 10V
Lamp Designation System	Lampenbezeichnungssystem	ZVEI - LBS
a) Numbers / Lamp Types Operated / Lumens [lm]	a) Lampen: Anzahl / Name / Leistung / Lichtstrom [lm]	2 x TC-DEL 18 W / 2x1.150 lm
b) Numbers / Lamp Types Operated / Lumens [lm]	b) Lampen: Anzahl / Name / Leistung / Lichtstrom [lm]	2 x TC-TEL 18 W / 2x1.150 lm
c) Numbers / Lamp Types Operated / Lumens [lm]	c) Lampen: Anzahl / Name / Leistung / Lichtstrom [lm]	
d) Numbers / Lamp Types Operated / Lumens [lm]	d) Lampen: Anzahl / Name / Leistung / Lichtstrom [lm]	
e) Numbers / Lamp Types Operated / Lumens [lm]	e) Lampen: Anzahl / Name / Leistung / Lichtstrom [lm]	
Dimmable	Dimmbar	<input type="checkbox"/> Yes <input checked="" type="checkbox"/> No
Dimming Range	Dimmbar von ... Bis	Min. 3% Max. 100%
Lamp Operating Frequency [KHz]	Lampenbetriebsfrequenz [kHz]	> 40
Ignition Method (PH, RS or IS)	Startmechanismus	<input checked="" type="checkbox"/> PH <input type="checkbox"/> RS <input type="checkbox"/> IS
Preheat Time [S]	Vorheizzeit [S]	0,4 < PT < 1,5
Lamp Current Crest Factor (CCF)	Lampenstromspitzenfaktor	< 1,7
Ballast (Lumen) Factor (BLF)	Ballast Lumen Faktor (BLF)	> 0.95
Automatic restart after lamp change	Autom. Wiederstart nach Lampenwechsel	<input checked="" type="checkbox"/> Yes <input type="checkbox"/> No
Thermal Protection (EN 61347-2-3)	Wärmeschutz (EN 61347-2-3)	<input checked="" type="checkbox"/> Yes <input type="checkbox"/> No
End Of Life (EOL) Protection	Sicherheitsabschaltung bei Lampendefekt	<input checked="" type="checkbox"/> Yes <input type="checkbox"/> No
Suitable for luminaires with protection class	Schutzklasse der Leuchten	<input checked="" type="checkbox"/> I <input type="checkbox"/> II
Suitable for luminaires with F-, M- or MM-Mark	Geeignet für Leuchten mit F-, M-, MM-Zeichen	<input checked="" type="checkbox"/> F <input checked="" type="checkbox"/> M <input checked="" type="checkbox"/> MM
Master Carton Quantity	Menge im Masterkarton	20
Label	Etikettengestaltung	<input checked="" type="checkbox"/> Fulham <input type="checkbox"/> Private
Weight [gr]	Gewicht [gr]	170
Case Dimensions-Length with Mount [mm]	Gehäusemass - Gesamt [mm]	L 123
Case Dimensions-Length w/o Mount [mm]	Gehäusemass - Befestigungsabstand [mm]	L 123
Case Dimensions-Length betw. mounting holes [mm]	Gehäusemass - Abstand Befestigungslöcher [mm]	L 129,5 (diagonal)
Case Dimensions-Width [mm]	Gehäusemass - Breite [mm]	W 79
Case Dimensions-Height [mm]	Gehäusemass - Höhe [mm]	H 31
Case Material	Gehäusematerial	Thermoplast (inflammable)
Primary strip length [mm]	Abisolierlänge Primärseitig [mm]	Min. 8 ... Max. 11
Secondary strip length [mm]	Abisolierlänge Sekundärseitig [mm]	Min. 8 ... Max. 11
Permissible cable lengths --- Hot wires [m]	Gestattete Leitungslänge - Hot [m]	0.5
Permissible cable lengths --- Cold wires [m]	Gestattete Leitungslänge - Cold [m]	2
EEL Classification	EEL Klassifizierung	EEL = A1
CE (with compliance RoHS)	CE (mit RoHS Tauglichkeit)	EN 61347-2-3
EMC Immunity	Immunität	EN 61547
Harmonic Content	Oberwellengehalt	IEC / EN 61000-3-2
Radio Interference Suppression	Funkstörung	DIN VDE 0875 / EN 55015
Performance ENEC	ENEC Prüfzeichen	IEC 60929
Approval Mark	Prüfzeichen	ENEC, VDE
Max. Case Hot Spot Temperature [°C]	Zulässige Gehäusetemperatur tc [°C]	+ 70
Max. Case Temperature in case of Failure [°C]	Max. Gehäusetemperatur im Fehlerfall [°C]	+110
Min. Ambient Temperature [°C]	Min. Umgebungstemperatur ta [°C]	+ 10
Max. Ambient Temperature [°C]	Max. Umgebungstemperatur ta [°C]	+ 50
Min. Storage Temperature [°C]	Min. Lagerungstemperatur [°C]	- 40
Max. Storage Temperature [°C]	Max. Lagerungstemperatur [°C]	+ 85
Product Life [h]	Produktlebensdauer [Std]	50000
Reliability [%]	Zuverlässigkeit [%]	90
Warranty [Years]	Garantiezeit [Jahre]	5



Fulham Company extends limited warranty only to the original purchaser or to the first user for the period of **5 years** from the date of manufacture as indicated by the date code stamped on each product and when properly installed and under normal conditions of use.

DUE TO A PROGRAM OF CONTINUOUS IMPROVEMENT, FULHAM Co., INC RESERVES THE RIGHT TO MAKE ANY VARIATION IN DESIGN OR CONSTRUCTION TO THE EQUIPMENT DESCRIBED.

Fulham Co., Inc. Address: 12705 South Van Ness Ave., Hawthorne, CA 90250 Tel.: 1-323-599-5000 Fax.: 1-323-754-9060 Website: www.fulham.com

2010-0302-2

Fulham Company GmbH Adresse: Karolinenstrasse 18, D-58507 Lüdenscheid, Germany Fon: +49 2351 4327416 Fax: +49 2351 6567349 Handelsregister Iserlohn: HR B 6286