

- LED Driver with integrated emergency backup
- Universal Voltage: 120-277V ~, 50/60Hz
- Output Wattage: 40W Max.
- Output Current: 250-1400mA
- Output voltage range of 11-55V $\overline{=}$
- Compact case with bottom studs and leads

This Driver Will Operate The Following LED Modules: Any LED module designed to accept constant input current of 250-1400mA and has a forward input voltage range of 11-55VDC .

General Specifications

Input Voltage	120-277VAC, 50/60Hz
Input Current	0.43A @ 120VAC
Input Power	54W
Power Factor	>0.9
THD	<20%
Standby Input Power	<0.85W
Driver Type	Constant Current
Output Current	250-1400mA [TPSB 100 (Program Box)] ; Record New Setting On 1"x0.5" Label
Output Voltage Range	11-28VDC (250-1400mA) , 11-40VDC (250-1000mA) , 11-55VDC (250-730mA)
Output Power	40W Max. 5W or 10W Initial @ Emergency Mode (Min. 180 Minutes Runtime @ 5W Setting , Min. 90Minutes Runtime @ 10W Setting)
Number of Output Channels	1 Channel
Dimming Controller Type / Dimming Range	0-10V / 100% - 1%,0% / Custom Dimming Curve / Dimmed To Off
RFI/EMI	FCC Part 15A Non-Consumer
Output Type	LED Class 2
Battery Type	LiFePO4 6.4VDC (Part# FHSBATL2-3.2L)
Battery Capacity Available	3200mAh
Battery Recharge Time	12 Hours
Max. Case Temperature	63°C(145.4°F)
Ambient Operating Temperature Range	0°C to 48°C(32°F to 118.4°F)
Sound Rating	A
Input Surge Protection	Line-Neutral 3kV , Line & Neutral-Gound 6kV , Ring Wave ANSI/IEEEC62.41
Protections	Input Current Protection Output Open Circuit Protection Overload Protection Over Temperature Protection Output Short Circuit Protection Output To Ground Short Circuit Protection
Service Life	50,000 hours
Approvals / Class	RoHS , cURus , CEC , Dry or Damp Locations

MECHANICAL DATA

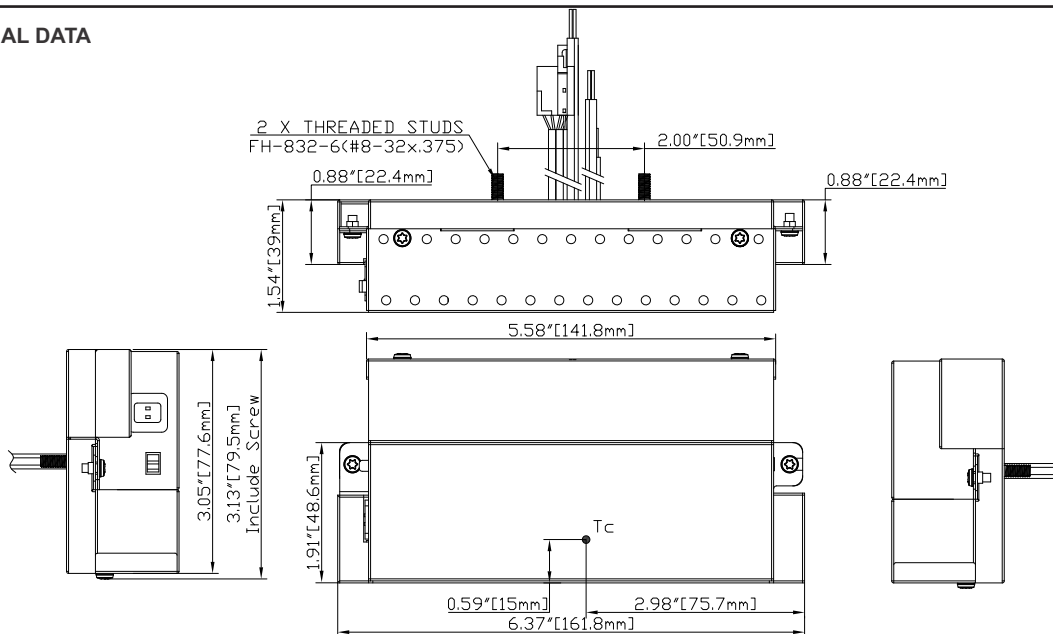

Fulham extends a limited warranty to the original purchaser or first user for a period of 5 years from the date of manufacture when properly installed and operated under normal conditions of use. For complete terms and conditions, please refer to the Warranty Center at www.fulham.com. Specifications subject to change without notice.

Important Safety Instructions

When using electrical equipment and this lighting device basic safety precaution should be followed at all times including but not limited to the following:

PLEASE READ CAREFULLY AND FOLLOW ALL INSTRUCTIONS FOR YOUR OWN SAFETY

- **IMPORTANT:** An un-switched AC power source of 120VAC to 277VAC is required for the yellow/black and white leads.
- **IMPORTANT:** A switched or un-switched AC power source of 120VAC to 277VAC is acceptable for the black lead only.
- This device is designed for use in fixtures listed for **dry and damp locations**.
- **CAUTION:** Make sure all electrical connections conform to the National Electrical Code and all applicable local regulations.
- **CAUTION:** Do not let power supply cords touch hot surfaces.
- **CAUTION:** Do not mount near gas or electric heaters.
- **CAUTION:** Do not use this emergency driver with accessory equipment other than recommended by manufacturer; failure to follow this may cause an unsafe condition. Servicing should only be performed by qualified service personnel.
- **CAUTION:** Do not use this emergency driver for other than intended use.
- **CAUTION:** Battery is rechargeable LiFePO4 type and must be recycled or disposed of properly.
- **CAUTION:** Equipment should be mounted in locations and at heights where it will not readily be subjected to tampering by unauthorized personnel.
- **CAUTION:** Not suitable for high-risk task area lighting.

ASSEMBLY and FIELD INSTALLATION WIRING: WARNING: AC power must be off before proceeding with assembly, installation or servicing of emergency driver. Additionally ensure that the battery is disconnected (Battery Switch set to OFF).

TESTING SYSTEM: The emergency battery requires a minimum charge time of one (1) hour before testing the circuit. A minimum of twelve (12) hours is required for a full charge.

RATED EMERGENCY OPERATION: Ninety (90) minutes for the 10W load or one hundred eighty (180) minutes for the 5W load. The 10W or 5W option is determined by the position of Dip Switch 1 (Emergency Power Selection Switch).

BATTERY DISABLE PROCEDURE: Unit must be powered within 6 months. To ship a fixture with the battery connected without draining the battery the procedure is:

1. Driver is installed in a fixture.
2. Battery is switched to the "ON" position.
3. Fixture is powered and tested.
4. Fixture is un-powered, the unit enters EM mode.
5. Battery is switched to "OFF", wait about 3 seconds then switch the battery back to the "ON" position.

Note: Not recommended for installations where unit will be without power for more than 6 months.

Fulham Head Quarters:
Fulham Co., Inc
12705 South Van Ness Ave.
Hawthorne, CA 90250

Manufacturer:
North China
Fulham Electronic Co. Ltd.
No. 9 Xingchang Road, Nanshao Zhen Changping Science Park, Beijing, P.R. China

SAVE THESE INSTRUCTIONS

Fulham extends a limited warranty to the original purchaser or first user for a period of 5 years from the date of manufacture when properly installed and operated under normal conditions of use. For complete terms and conditions, please refer to the Warranty Center at www.fulham.com. Specifications subject to change without notice.

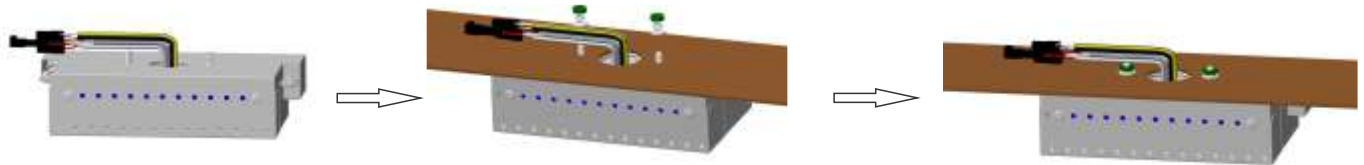

Screw the nut

NOTE : Two Ø5mm holes with a spacing of 50.8mm are needed for the installation of this driver;
One hole(≥Ø26mm) at the midpoint of the above mentioned two holes is necessary for wiring.

A Mounting the LED driver

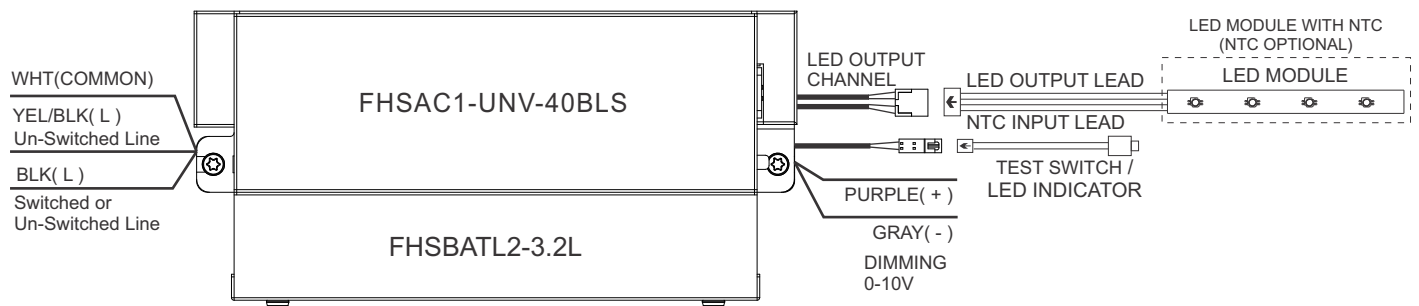

Case	Dimensions
Length	6.32"[160.5mm]
Width	3.05"[77.6mm]
Height	1.54"[39mm]

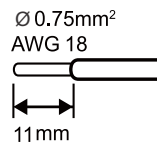

INPUT SIDE	LENGTH
BLACK	8.86"[225mm]
WHITE	8.86"[225mm]
YEL/BLK	12.80"[325mm]

OUTPUT SIDE	LENGTH
LED OUTPUT	4.53"[115mm]
TEST LEAD	4.53"[115mm]
PURPLE	8.86"[225mm]
GRAY	8.86"[225mm]

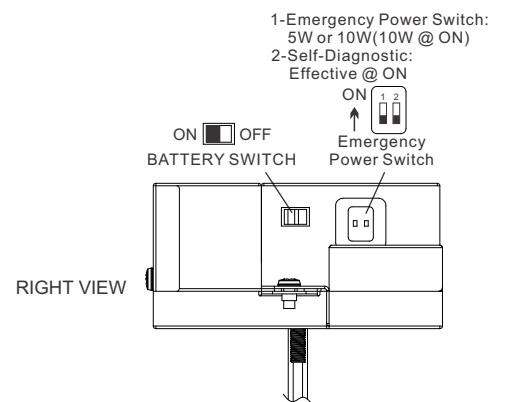

NOTE: 1.The driver must be grounded.
2.Once assembly, installation or servicing is complete, set the BATTERY SWITCH to the ON position.

B Wiring diagram

Fulham extends a limited warranty to the original purchaser or first user for a period of 5 years from the date of manufacture when properly installed and operated under normal conditions of use. For complete terms and conditions, please refer to the Warranty Center at www.fulham.com. Specifications subject to change without notice.

BATTERY REPLACEMENT/SERVICING INSTRUCTION

Warning: Disconnect power when servicing fixture.

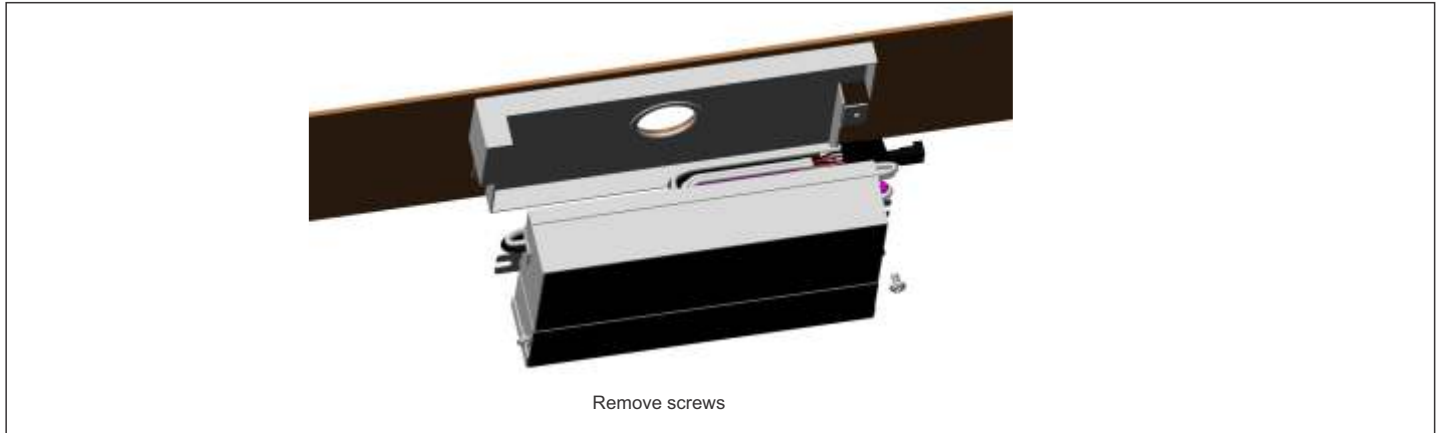

STEP 1: Remove the LED driver from the bottom feed cover



STEP 2: Remove the cover

C Removing LED driver and cover



STEP 1: Install new battery and re-assemble battery cover

D Replacing battery and re-installing LED driver

Fulham extends a limited warranty to the original purchaser or first user for a period of 5 years from the date of manufacture when properly installed and operated under normal conditions of use. For complete terms and conditions, please refer to the Warranty Center at www.fulham.com. Specifications subject to change without notice.

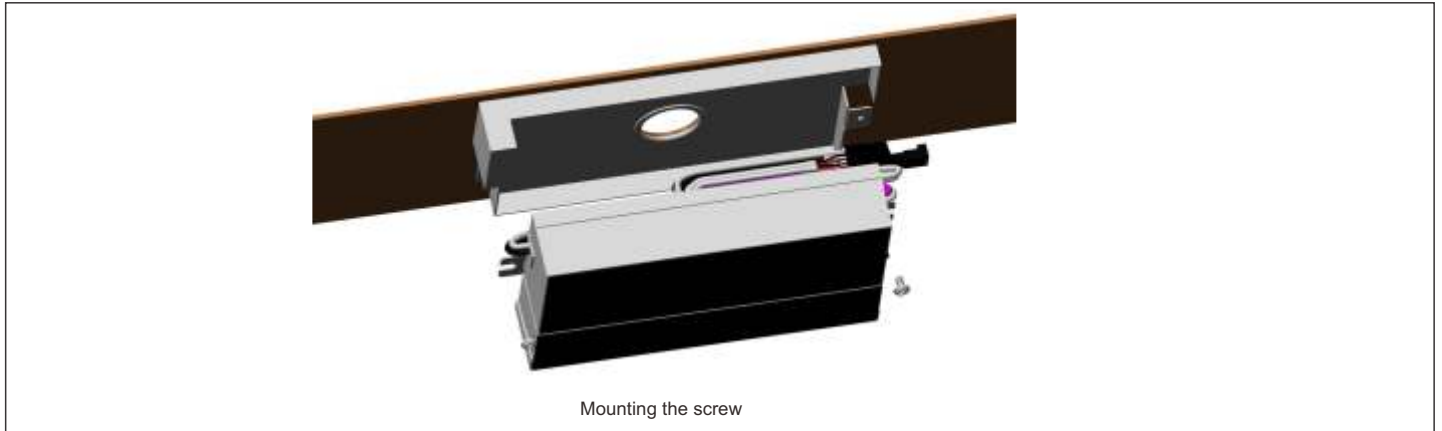

STEP 2: Re-assemble LED driver to bottom feed cover

D Replacing battery and re-installing LED driver



Completed Assembly



Exploded View

SAVE THESE INSTRUCTIONS

Fulham extends a limited warranty to the original purchaser or first user for a period of 5 years from the date of manufacture when properly installed and operated under normal conditions of use. For complete terms and conditions, please refer to the Warranty Center at www.fulham.com. Specifications subject to change without notice.

Guideline on calculating emergency illumination level

The purpose of this guideline is to identify the illumination level of the LED luminaire when used with Fulham's FHSAC1-UNV-40BLS LED emergency driver. The path of egress illumination level during emergency operation is determined by types of luminaires, Luminaire Efficacy, Luminaire Mounting Height, Emergency Power and some other effects in real application.

Step 1: Select an LED Luminaire, and make sure the LED light source is electrically compatible with Fulham's LED emergency driver. Get the Light Distribution data (usually an .ies file) and Rated Efficacy data (lumen per watt) from luminaire supplier.

If the luminaire is DesignLights Consortium™ (DLC) compliant, you can also get the efficacy information from DLC website.

- Open DLC Qualified Product List(QPL) database search page: <https://www.designlights.org/search/>
- Searching keywords by model, brand name or manufacturer for the luminaire used.
- Find the "Efficacy" data listed on website or calculated by dividing "Light output" by "Wattage", the efficacy value should be shown in lumen per watt (lm/W).

If the luminaire is ENERGY STAR compliant, you can also get the luminaire efficacy information from ENERGY STAR website.

- Open ENERGY STAR certified Light Fixtures database search page: <https://www.energystar.gov/productfinder/product/certified-light-fixtures/results>
- Searching keywords by model, brand name or manufacturer for the luminaire used.
- Find the "Energy Efficiency" data listed on website. If it is showed as "Measured at the Source", please contact with luminaire supplier for additional light loss for this light source inside the fixture. The value should be shown in lumen per watt (lm/W).

Step 2: Determine the Emergency Power and calculate the Emergency Light Output.

FHSAC1-UNV-40BLS is programmable output; setting a proper Emergency Power is vital to achieve desired illumination.

Emergency Light Output is equal to the Emergency Power multiply by luminaire efficacy. For example, if the luminaire is 120lm/W and in 3W emergency operation, the total Emergency Light Output is 120lm/W * 3W = 360lm.

Step 3: Use industry lighting design software to calculate the illumination level according to the luminaire layout in room, luminaire mounting height, the original .ies file and Emergency Light Output calculated above. If the illumination level cannot meet life safety codes, go back to Step2 to use a higher Emergency Power or go back to Step1 to select a higher efficacy luminaire or use more luminaires in the room.

Fulham's FHSAC1-UNV-40BLS LED emergency driver is compliant with UL 924 standard, according to UL test data, Table 1 and Table 2 below give basic indication to determine the min. Emergency Power and Luminaire Max. Mounting Height for 1 foot-candle illumination based on a single luminaire with typical Lambertian distribution. It is the light designer/ construction contractor's responsibility to validate the real illumination level on site, to assure the emergency light illumination level is in accordance with the requirement of Federal, state and local municipal codes. It may diff to the theoretical calculation or simulation on computer.

Table 1. Min. EM Power for 1fc @ 10ft vs. Luminaire Efficacy

Luminaire Efficacy (lm/W)	Min. EM Power to achieve 1 fc @ 10ft Mounting Height
80	5.0 W

Table 2. Max. Mounting Height vs. Luminaire Efficacy

Luminaire Efficacy (lm/W)	Max. Mounting Height for 1fc	
	EM 5W	EM 10W
80	10.1 ft	13.9 ft
100	11.2 ft	15.4 ft
120	12.1 ft	16.8 ft
140	13.0 ft	18.1 ft
160	13.9 ft	19.3 ft
180	14.6 ft	20.4 ft

SELF DIAGNOSTIC INSTRUCTIONS / OPERATION:

If Dip Switch 2 (Self-Diagnostic Switch) is set to the OFF position:

The self diagnostic feature is disable. A functionality test shall be manually conducted every thirty(30) days to ensure the emergency LED light source illuminates as intended. A full discharge test shall be conducted once a year; the LED light source shall illuminate for a minimum of ninety (90) minutes for the 10W load (Dip Switch 1 is set to the ON position) or one hundred eighty (180) minutes for 5W load (Dip Switch 1 is set to the OFF position).

If Dip Switch 2 (Self-Diagnostic Switch) is set to the ON position:

The self diagnostic feature is enable .The emergency LED driver will conduct a self check for thirty (30) seconds every thirty (30) days; and ninety (90) minutes or one hundred eighty (180) minutes self check every 12 months. After every self check the LED indicator light will indicate a status signal. A single self-diagnostic test can be activated by pressing the test switch three (3) times. Refer to Indicators Status Table for details.

When user toggle the Dip Switch, the LED indicator on Switch button would flash 3 times, 2.5S ON/0.5S OFF for Enabled, while 0.5S ON/2.5S OFF for Disabled.

TEST SWITCH INDICATOR STATUS:

LED Indicators Status	EM Driver Status/Mode
• Solid Green	System OK/AC OK(Self-diagnostic Enabled or Disabled).
• Slow Flashing Red, 4s on/1s off	Battery not detected, check battery switch or connection.
• Flashing Red, 1s on/1s off	Battery Failure, replace battery.
• Flashing Green, 1s on/1s off	Self-Diagnostic test underway.
• Fast Flashing Red, 0.1s on/0.1s off	Abnormal driver performance, replace driver.
• Very Slow Flashing Red, 4s on/4s off	Over temperature.
• None. Both LEDs OFF	Normal working in EM mode.
• Green/Red alternative flashing, 1s green/1s red.	No load or output over voltage protection triggered.

TEST SWITCH OPERATIONS:

1. EM Test: Press and hold test button (>1s)to enter EM mode for testing in normal AC powered .
2. Manual Self-Diagnostic(When Self-Diagnostic Enabled - Dip Switch 1 set to the ON position): After charging twelve (12) hours or battery fully charged, quickly press the test button three(3) times within three(3) seconds to force the controller to enter a Self-Diagnostic cycle. To quit the self-diagnostic cycle after engaged press and hold the test button for ten(10) seconds.

Programming:

This driver can be programmed using the TPSB-100(E). Programming features include the following:

- * Output Current :250-1400mA
- * Dimming Curve
- * LED NTC Thermal Protection



Fulham extends a limited warranty to the original purchaser or first user for a period of 5 years from the date of manufacture when properly installed and operated under normal conditions of use. For complete terms and conditions, please refer to the Warranty Center at www.fulham.com. Specifications subject to change without notice.