



FHNY20



New York City Code Steel Emergency Exit Sign

- Push-to-test switch
- LED charge indicator
- Specification grade design
- Heavy duty 20 gauge construction
- Maintenance free, 3.6V lead-acid battery
- Universal mount
- Dual voltage 120V/277V
- White powder coat finish
- Universal single face and double face (extra faceplate included)
- New York city approved

General Specifications

	AC (AC Only)	EM (Battery Backup)
Input Voltage	120/277VAC	
Input Current (120V)	61mA	39mA
Input Current (277V)	31mA	17mA
Input Power (120V)	6.6W	4.5W
Input Power (277V)	7.9W	4.8W
Operating Frequency	60Hz	
Operating Ambient Temperature Range (Ta)	20° to 30°C / 68°F to 86°F	
Overall Size	14.5" L x 10.5" H	
Emergency Operation	90 minutes	
Compliance	UL 924 Listed Damp Location	
Warranty	5 years from the date of manufacture	

Mechanical Data

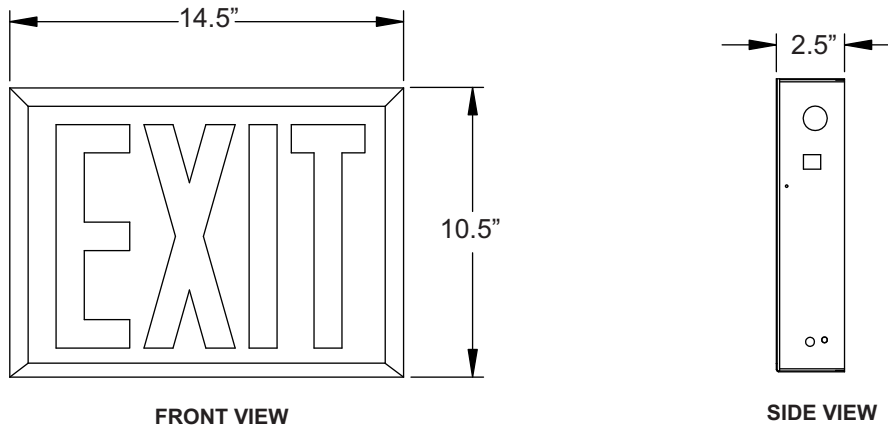

Part Number Matrix

FHNY20

AC

Operation
AC = AC Only
EM = Battery Backup