

**SPECIFICATION SHEET : WHSG6 MLT T12 RS**

This Is An Original Product From Fulham Electronic Co., Ltd

**Description : WORKHORSE Specifier Grade Series Electronic Ballast, Drop In Replacement for Magnetic Ballast, Parallel Lamp Operation, THD Less Than 10%**

**This Ballast Will Operate Following Lamps.**

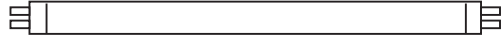

**F18T8 / F20T12 / F36T8 / F40T12**

**ELECTRICAL DATA ( With 120 Volt Application )**

INPUT VOLT: 120V/240V, 50/60Hz							
LAMP WATTS/TYPE	F18 T8	F20T12	F18 T8	F36T8	F20T12	F40T12	
LAMPS OPERATED	2		1				
INPUT WATTS	35.21W	36.78W	19.75W	34.19W	21.05W	32.91W	
LINE CURRENT	0.292A	0.292A	0.166A	0.284A	0.176A	0.275A	
POWER FACTOR	>0.95						
BALLAST FACTOR	0.9						
EFFICACY FACTOR	>88%						
THD	<10%						
CURRENT CREST FACTOR	< 1.7						
EMI/RFI COMPLIANCE	FCC PART 18-A (None Consumer)						
SOUND RATING	" A "						
BALLAST TYPE	RAPID START						
VOLTAGE TRANSIENTS	ANSI 62.41						
INPUT/PROTECTION	FUSE						
OUTPUT/PROTECTION	EOL						
MIN. OPERATING TEMP	- 10 °C ( 14 ° F )						
MAX. CASE TEMP	75 °C ( 167 ° F )						
ENERGY STAR 4.0	-						
APPROVALS/CLASS	UL LISTED, CLASS " P ", 1 OUTDOOR						

**MECHANICAL DATA**

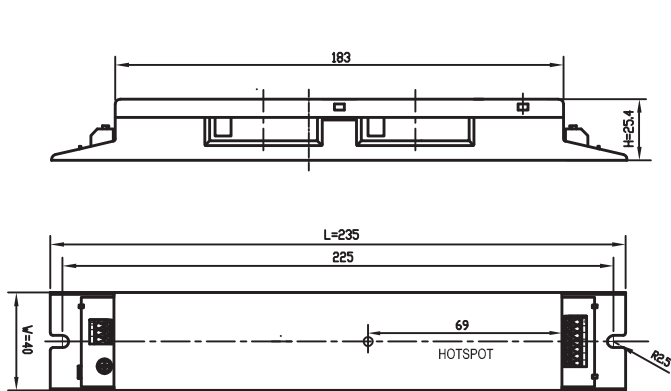

Where : L = Length, W = Width, H = Height

**WIRING DIAGRAMS**

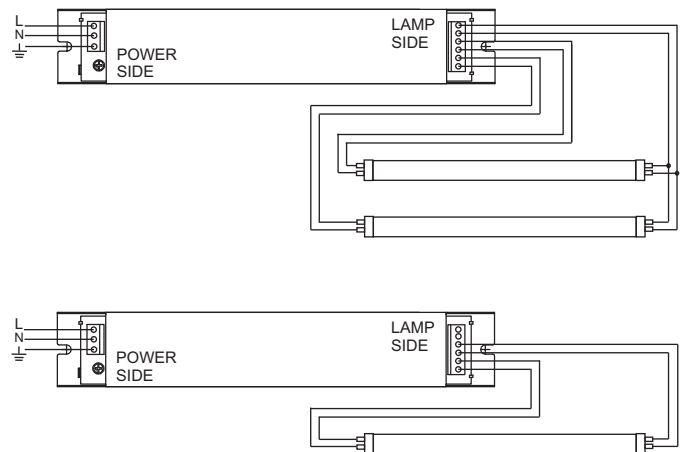

**NOTE : This Ballast Must Be Grounded**

Fulham Electronic Co., Ltd extends limited warranty only to the original purchaser or to the first user for the period of 3 years from the date of manufacture when properly installed and under normal conditions of use.

DUE TO A PROGRAM OF CONTINUOUS IMPROVEMENT, FULHAM ELECTRONIC Co.,LTD RESERVES THE RIGHT TO MAKE ANY VARIATION IN DESIGN OR CONSTRUCTION TO THE EQUIPMENT DESCRIBED.

Address : Unit 2617 Miramar Tower 132 Nathan Road, T S T .Kowloon Hong Kong Tel.:852 2314 4801, Fax.: 852 2314 4186

Website [www.fulham.com](http://www.fulham.com)

**SPECIFICATION SHEET : WHSG6 MLT T12 RS**

This Is An Original Product From Fulham Electronic Co., Ltd

**Description : WORKHORSE Specifier Grade Series Electronic Ballast, Drop In Replacement for Magnetic Ballast, Parallel Lamp Operation, THD Less Than 10%**

**This Ballast Will Operate Following Lamps.**

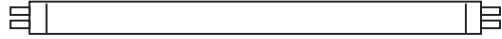

F18T8 / F20T12 / F36T8 / F40T12

**ELECTRICAL DATA ( With 240 Volt Application )**

INPUT VOLT: 120V/240V, 50/60Hz							
LAMP WATTS/TYPE	F18 T8	F20T12	F18 T8	F36T8	F20T12	F40T12	
LAMPS OPERATED	2		1				
INPUT WATTS	34.64W	35.34W	19.75W	33.57W	21.14W	32.66W	
LINE CURRENT	0.158A	0.160A	0.093A	0.153A	0.100A	0.150A	
POWER FACTOR	>0.95						
BALLAST FACTOR	0.9						
EFFICACY FACTOR	>88%						
THD	<10%						
CURRENT CREST FACTOR	< 1.7						
EMI/RFI COMPLIANCE	FCC PART 18-A (None Consumer)						
SOUND RATING	" A "						
BALLAST TYPE	RAPID START						
VOLTAGE TRANSIENTS	ANSI 62.41						
INPUT/PROTECTION	FUSE						
OUTPUT/PROTECTION	EOL						
MIN. OPERATING TEMP	- 10 °C ( 14 ° F )						
MAX. CASE TEMP	75 °C ( 167 ° F )						
ENERGY STAR 4.0	-						
APPROVALS/CLASS	UL LISTED, CLASS " P ", 1 OUTDOOR						

**MECHANICAL DATA**

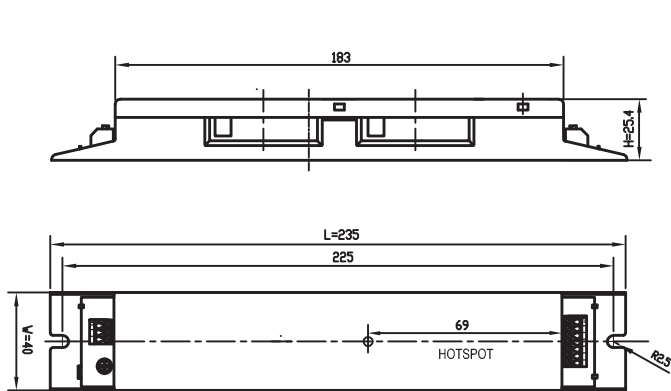

Where : L = Length, W = Width, H = Height

**WIRING DIAGRAMS**

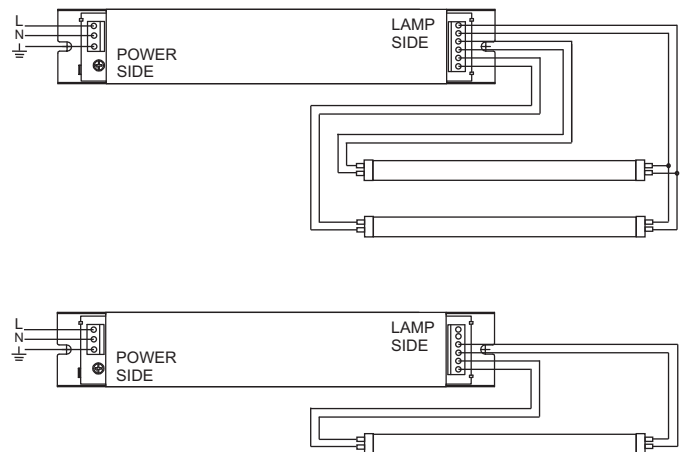

NOTE : This Ballast Must Be Grounded

Fulham Electronic Co., Ltd extends limited warranty only to the original purchaser or to the first user for the period of 3 years from the date of manufacture when properly installed and under normal conditions of use.

DUE TO A PROGRAM OF CONTINUOUS IMPROVEMENT, FULHAM ELECTRONIC Co.,LTD RESERVES THE RIGHT TO MAKE ANY VARIATION IN DESIGN OR CONSTRUCTION TO THE EQUIPMENT DESCRIBED.

Address : Unit 2617 Miramar Tower 132 Nathan Road, T S T .Kowloon Hong Kong Tel.:852 2314 4801, Fax.: 852 2314 4186

Website www fulham com