

SPECIFICATION SHEET : WHSG5 MLT T12 RS

This Is An Original Product From Fulham Electronic Co., Ltd

Description : WORKHORSE Specifier Grade Series Electronic Ballast, Drop In Replacement for Magnetic Ballast, Parallel Lamp Operation, THD Less Than 10%

This Ballast Will Operate Following Lamps.

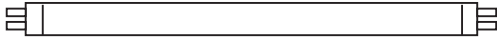

F36T8 / F40T12

ELECTRICAL DATA (With 120 Volt Application)

INPUT VOLT: 120V/240V , 50/60Hz				
LAMP WATTS/TYPE	F36 T8	F40 T12	F36 T8	F40 T12
LAMPS OPERATED	1		2	
INPUT WATTS	39.59W	39.31W	68.84W	68.46W
LINE CURRENT	0.330A	0.335A	0.576A	0.574A
POWER FACTOR	>0.95			
BALLAST FACTOR	0.9			
EFFICACY FACTOR	>88%			
THD	<10%			
CURRENT CREST FACTOR	< 1.7			
EMI/RFI COMPLIANCE	FCC PART 18-A (None Consumer)			
SOUND RATING	" A "			
BALLAST TYPE	RAPID START			
VOLTAGE TRANSIENTS	ANSI 62.41			
INPUT/PROTECTION	FUSE			
OUTPUT/PROTECTION	EOL			
MIN. OPERATING TEMP	- 10 °C (14 ° F)			
MAX. CASE TEMP	75 °C (167 ° F)			
ENERGY STAR 4.0	-			
APPROVALS/CLASS	UL LISTED, CLASS " P ", 1 OUTDOOR			

MECHANICAL DATA

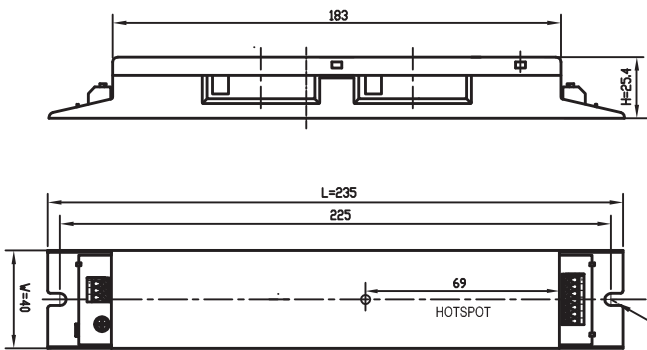

Where : L = Length, W = Width, H = Height

WIRING DIAGRAMS

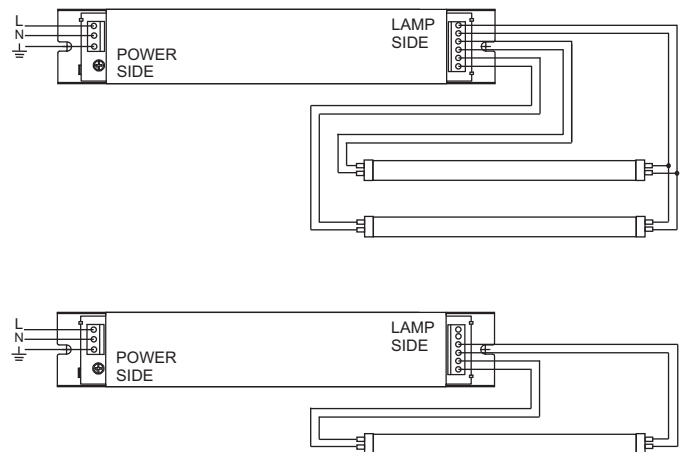

NOTE : This Ballast Must Be Grounded

Fulham Electronic Co., Ltd extends limited warranty only to the original purchaser or to the first user for the period of 3 years from the date of manufacture when properly installed and under normal conditions of use.

DUE TO A PROGRAM OF CONTINUOUS IMPROVEMENT, FULHAM ELECTRONIC Co.,LTD RESERVES THE RIGHT TO MAKE ANY VARIATION IN DESIGN OR CONSTRUCTION TO THE EQUIPMENT DESCRIBED.

Address : Unit 2617 Miramar Tower 132 Nathan Road, T S T .Kowloon Hong Kong Tel.:852 2314 4801, Fax.: 852 2314 4186

Website www.fulham.com

SPECIFICATION SHEET : WHSG5 MLT T12 RS

This Is An Original Product From Fulham Electronic Co., Ltd

Description : WORKHORSE Specifier Grade Series Electronic Ballast, Drop In Replacement for Magnetic Ballast, Parallel Lamp Operation, THD Less Than 10%

This Ballast Will Operate Following Lamps.

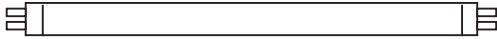

F36T8 / F40T12

ELECTRICAL DATA (With 240 Volt Application)

INPUT VOLT: 120V/240V , 50/60Hz				
LAMP WATTS/TYPE	F36 T8	F40 T12	F36 T8	F40 T12
LAMPS OPERATED	1		2	
INPUT WATTS	39.28W	39.80W	67.52W	67.30W
LINE CURRENT	0.182A	0.183A	0.309A	0.308A
POWER FACTOR	>0.95			
BALLAST FACTOR	0.9			
EFFICACY FACTOR	>88%			
THD	<10%			
CURRENT CREST FACTOR	< 1.7			
EMI/RFI COMPLIANCE	FCC PART 18-A (None Consumer)			
SOUND RATING	" A "			
BALLAST TYPE	RAPID START			
VOLTAGE TRANSIENTS	ANSI 62.41			
INPUT/PROTECTION	FUSE			
OUTPUT/PROTECTION	EOL			
MIN. OPERATING TEMP	- 10 °C (14 ° F)			
MAX. CASE TEMP	75 °C (167 ° F)			
ENERGY STAR 4.0	-			
APPROVALS/CLASS	UL LISTED, CLASS " P " , 1 OUTDOOR			

MECHANICAL DATA

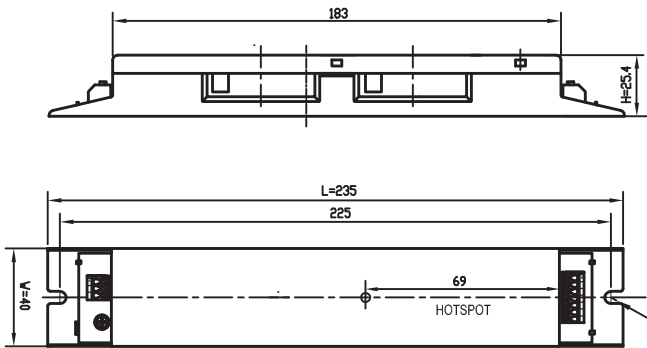

Where : L = Length, W = Width, H = Height

WIRING DIAGRAMS

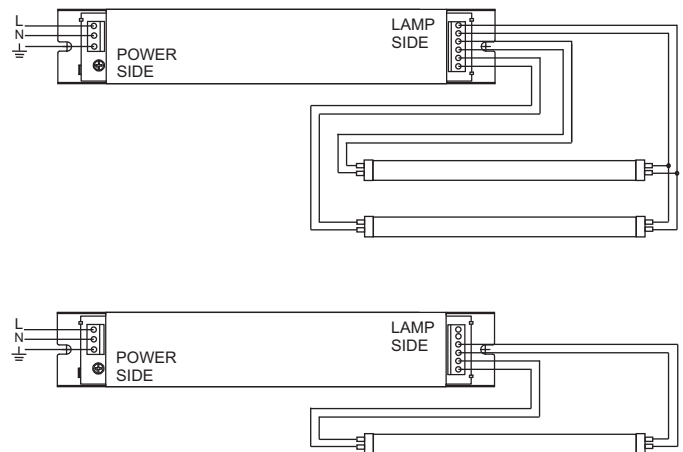

NOTE : This Ballast Must Be Grounded

Fulham Electronic Co., Ltd extends limited warranty only to the original purchaser or to the first user for the period of 3 years from the date of manufacture when properly installed and under normal conditions of use.

DUE TO A PROGRAM OF CONTINUOUS IMPROVEMENT, FULHAM ELECTRONIC Co.,LTD RESERVES THE RIGHT TO MAKE ANY VARIATION IN DESIGN OR CONSTRUCTION TO THE EQUIPMENT DESCRIBED.

Address : Unit 2617 Miramar Tower 132 Nathan Road, T S T .Kowloon Hong Kong Tel.:852 2314 4801, Fax.: 852 2314 4186

Website www.fulham.com