

SPECIFICATION SHEET : WHSG5-127-T12-RS

This Is An Original Product From Fulham Electronic Co., Ltd

Description : WORKHORSE Specifier Grade Series Electronic Ballast, Drop In Replacement for Magnetic Ballast, Parallel Lamp Operation, THD Less Than 10%

This Ballast Will Operate Following Lamps.

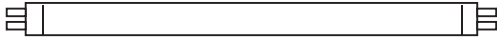

F36T8 / F40T12

ELECTRICAL DATA

INPUT VOLT: 127V ± 10%, 50/60Hz				
LAMP WATTS/TYPE	F36 T8	F40 T12	F36 T8	F40 T12
LAMPS OPERATED	1		2	
INPUT WATTS	43W	44W	73W	75W
LINE CURRENT	0.343A	0.348A	0.584A	0.597A
POWER FACTOR	>0.95			
BALLAST FACTOR	1			
EFFICACY FACTOR	>88%			
THD	<10%			
CURRENT CREST FACTOR	< 1.7			
EMI/RFI COMPLIANCE	-			
SOUND RATING	-			
BALLAST TYPE	RAPID START			
VOLTAGE TRANSIENTS	-			
INPUT/PROTECTION	FUZE			
OUTPUT/PROTECTION	EOL			
MIN. OPERATING TEMP	- 10 °C (14 ° F)			
MAX. CASE TEMP	75 °C (167 ° F)			
ENERGY STAR 4.0	-			
APPROVALS/CLASS	UL LISTED, CLASS " P ", 1 OUTDOOR			

MECHANICAL DATA

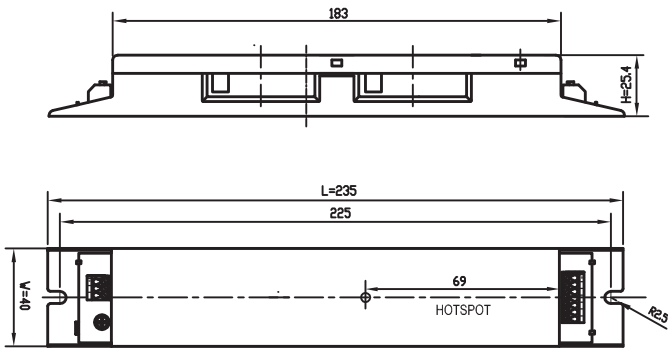

Where : L = Length, W = Width, H = Height

WIRING DIAGRAMS

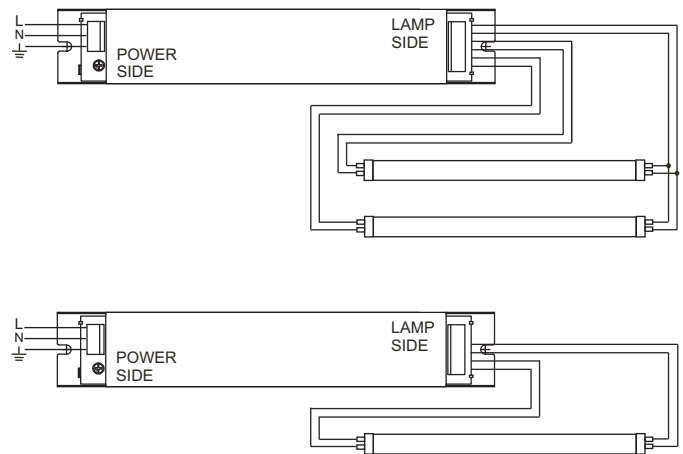

NOTE : This Ballast Must Be Grounded

Fulham Electronic Co., Ltd extends limited warranty only to the original purchaser or to the first user for the period of **3 years** from the date of manufacture when properly installed and under normal conditions of use.

DUE TO A PROGRAM OF CONTINUOUS IMPROVEMENT, FULHAM ELECTRONIC Co.,LTD RESERVES THE RIGHT TO MAKE ANY VARIATION IN DESIGN OR CONSTRUCTION TO THE EQUIPMENT DESCRIBED.

Address : 12705 South Van Ness Ave. , Hawthorne CA 90250, U. S. A Tel.:323-599-5001 Website: www.fulham.com