

**SPECIFICATION SHEET : WHCG5-127-T12-RS-L**

This Is An Original Product From Fulham Electronic Co., Ltd

**Description : WORKHORSE Commercial Grade Series Electronic Ballast, Drop In Replacement for Magnetic Ballast, Parallel Lamp Operation, THD Less Than 25%**

**This Ballast Will Operate Following Lamps.**

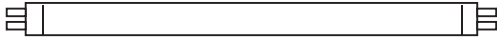

**F36T8 / F40T12**

**ELECTRICAL DATA**

INPUT VOLT: 127V ± 10%, 50/60Hz				
LAMP WATTS/TYPE	F36 T8		F40 T12	
LAMPS OPERATED	1	2	1	2
INPUT WATTS	37W	69W	39W	69W
LINE CURRENT	0.301A	0.548A	0.310A	0.550A
POWER FACTOR	>0.85			
BALLAST FACTOR	0.9			
EFFICIENCY	>88%			
THD	<25%			
CURRENT CREST FACTOR	< 1.7			
EMI/RFI COMPLIANCE	-			
SOUND RATING	-			
BALLAST TYPE	RAPID START			
VOLTAGE TRANSIENTS	-			
INPUT/PROTECTION	FUZE			
OUTPUT/PROTECTION	EOL			
MIN. OPERATING TEMP	- 10 °C ( 14 ° F )			
MAX. CASE TEMP	75 °C ( 167 ° F )			
ENERGY STAR 4.0	-			
APPROVALS/CLASS	-			

**MECHANICAL DATA**

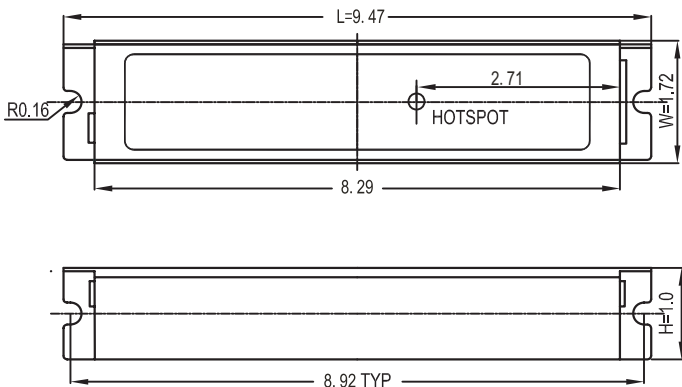

Where : L = Length, W = Width, H = Height

**WIRING DIAGRAMS**

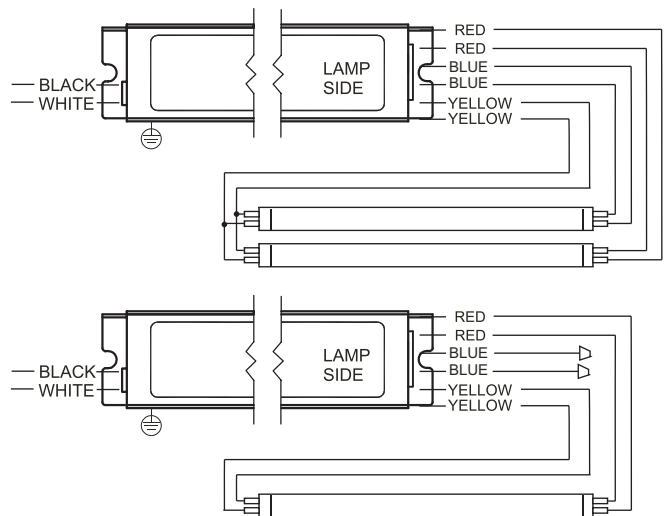

**NOTE : This Ballast Must Be Grounded**

Fulham Electronic Co., Ltd extends limited warranty only to the original purchaser or to the first user for the period of 3 years from the date of manufacture when properly installed and under normal conditions of use.

DUE TO A PROGRAM OF CONTINUOUS IMPROVEMENT, FULHAM ELECTRONIC Co.,LTD RESERVES THE RIGHT TO MAKE ANY VARIATION IN DESIGN OR CONSTRUCTION TO THE EQUIPMENT DESCRIBED.

Address : 12705 South Van Ness Ave. , Hawthorne CA 90250, U. S. A Tel.:323-599-5001 Website: www.fulham.com