



**Discontinued**  
Contact Fulham for availability. Not for use in new designs.

**SPECIFICATION SHEET : SC-230-213-LT5**

This Is An Original Product From Fulham Co., Inc

**Description : PONY Series, High Frequency Electronic, Rapid Start Ballast, \* Meets Energy Star 4.0 Criteria For Applications Listed.**

**This Ballast Will Operate Following Lamps.**

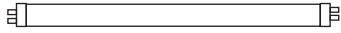

**F8T5 / F13T5 / F14T5 / F21T5**

**ELECTRICAL DATA**

INPUT VOLT: 230V ± 10%, 50/60Hz								
LAMP WATTS/TYPE	F8T5 + F13T5	F21T5	F8T5	F13T5	F14T5	-	-	-
LAMPS OPERATED	1	1	2	2	2			
INPUT WATTS	23.52	24.02	20.81	32.24	31.78			
LINE CURRENT:	0.189	0.193	0.177	0.255	0.249			
POWER FACTOR	0.542	0.542	0.512	0.551	0.555			
BALLAST FACTOR	0.934	0.933	1.043	0.937	0.847			
EFFICACY FACTOR	3.970	3.884	5.012	2.892	2.665			
THD	146.00	144.40	159.30	142.70	138.50			
CURRENT CREST FACTOR	< 1.7							
EMI/RFI COMPLIANCE	FCC PART 18-A (Non-Consumer)							
SOUND RATING	" A "							
BALLAST TYPE	RAPID START							
VOLTAGE TRANSIENTS	ANSI 62.41							
INPUT/PROTECTION	FUSE							
OUTPUT/PROTECTION	EOL							
MIN. OPERATING TEMP	0 °C ( 32 °F )							
MAX. CASE TEMP	75 °C ( 167 °F )							

**MECHANICAL DATA**

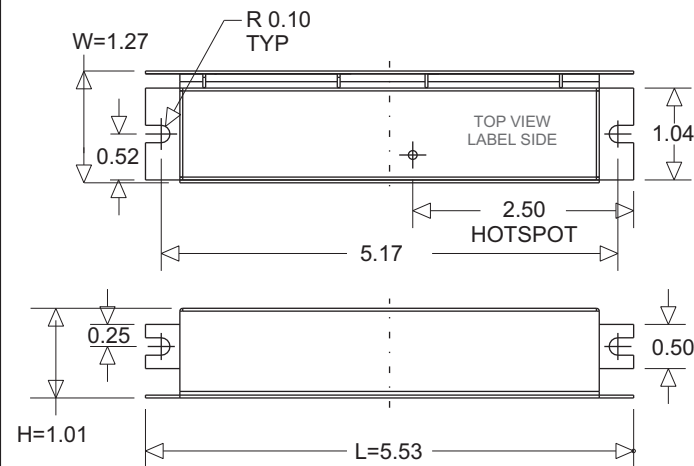

Where : L = Length, W = Width, H = Height

**WIRING DIAGRAMS**

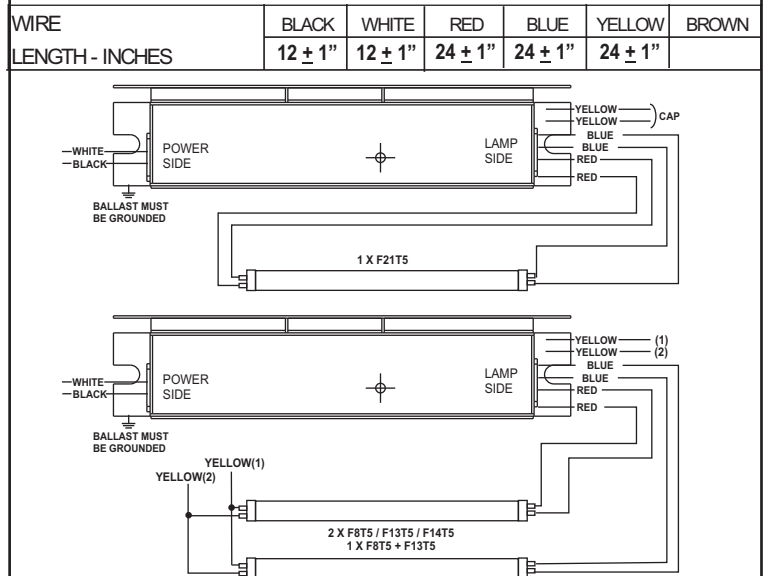

**NOTE : This Ballast Case Must Be Grounded**

Fulham Co., Inc extends limited warranty only to the original purchaser or to the first user for the period of 2 years from the date of manufacture as indicated by the date code stamped on each product and when properly installed and under normal conditions of use. For additional warranty guide line, please refer to our Complete Product Catalog OR call Customer Service at 1-800-2-Fulham.

DUE TO A PROGRAM OF CONTINUOUS IMPROVEMENT, FULHAM Co., INC RESERVES THE RIGHT TO MAKE ANY VARIATION IN DESIGN OR CONSTRUCTION TO THE EQUIPMENT DESCRIBED.

Address : 12705 South Van Ness Ave., Hawthorne, CA 90250 Tel.: 1-800-2-fulham, Fax.: 1-323-754-9060. Website: [www.fulham.com](http://www.fulham.com)