

## SPECIFICATION SHEET : NPY-120-228-LT5

This Is An Original Product From Fulham Co., Inc

**Description : PONY Series, High Frequency Electronic, Rapid Start Ballast,**  
**\* Meets Energy Star 4.0 Criteria For Applications Listed.**

**This Ballast Will Operate Following Lamps.**



**F28T5**

### ELECTRICAL DATA

INPUT VOLT: 120V ± 10%, 50/60Hz									
LAMP WATTS/TYPE	F28T5	F28T5	-	-	-	-	-	-	-
LAMPS OPERATED	1	2							
INPUT WATTS	36.06	67.64							
LINE CURRENT:	0.597	1.051							
POWER FACTOR	0.529	0.536							
BALLAST FACTOR	1.045	0.944							
EFFICACY FACTOR	2.899	1.396							
THD	163.20	136.80							
CURRENT CREST FACTOR	< 1.7								
EMI/RFI COMPLIANCE	FCC PART 18-B (Consumer)								
SOUND RATING	" A "								
BALLAST TYPE	RAPID START								
VOLTAGE TRANSIENTS	ANSI 62.41								
INPUT/PROTECTION	FUSE								
OUTPUT/PROTECTION	EOL								
MIN. OPERATING TEMP	0 °C ( 32 ° F )								
MAX. CASE TEMP	75 °C ( 167 ° F )								
ENERGY STAR 4.0	-								
APPROVALS/CLASS	UL /cUL LISTED, CLASS " P ", 1 OUTDOOR								

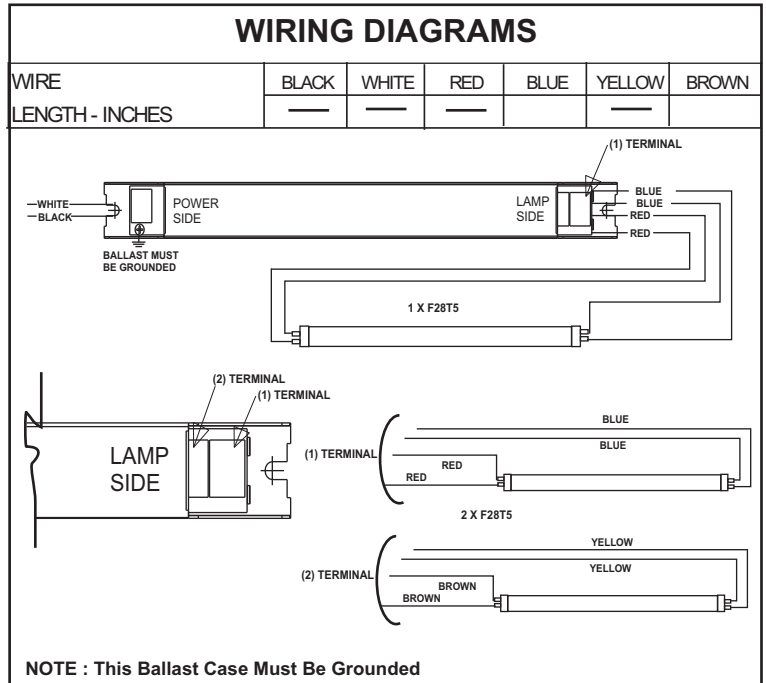
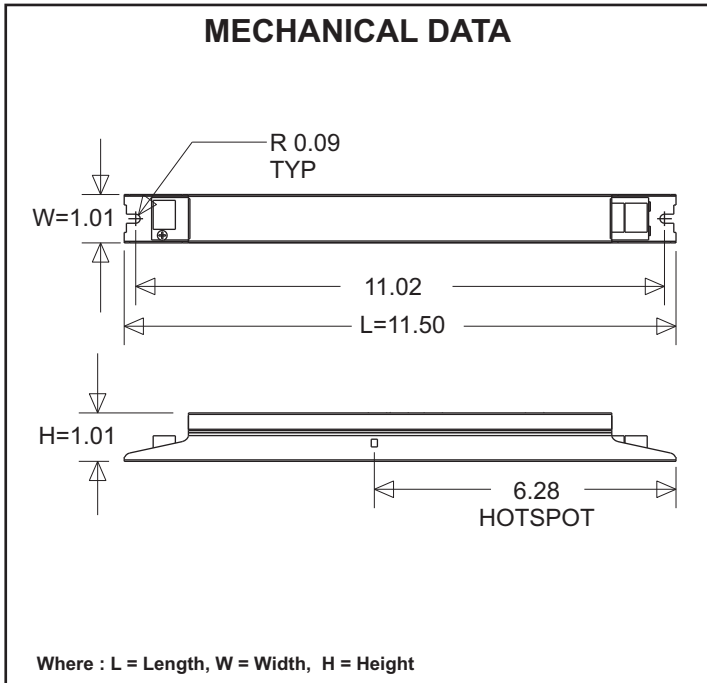

Fulham extends a limited warranty only to the original purchaser or to the first user for a period of 2 years from the date of manufacture when properly installed and operated under normal conditions of use. For complete terms and conditions, please reference the Fulham product catalog ([www.fulham.com](http://www.fulham.com))  
**Due to a program of continuous improvement, Fulham reserves the right to make modifications or variations in design or construction to the equipment described.**