



Discontinued
Contact Fulham for availability. Not for use in new designs.

SPECIFICATION SHEET : WHCG6- 220- T12- RS- L

This Is An Original Product From Fulham Electronic Co., Ltd

Description : WORKHORSE Commercial Grade Series Electronic Ballast, Drop In Replacement for Magnetic Ballast, Parallel Lamp Operation, THD Less Than 25%

This Ballast Will Operate Following Lamps.

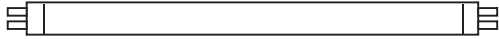

F18T8 / F20T12

ELECTRICAL DATA

INPUT VOLT: 220V ± 10%, 50/60Hz				
LAMP WATTS/TYPE	F18 T8	F20T12	F18 T8	F20T12
LAMPS OPERATED	2	2	1	1
INPUT WATTS	34W	34W	-	-
MAX. LINE CURRENT	0.158A	0.157A	-	-
POWER FACTOR	>0.85			
BALLAST FACTOR	0.9			
EFFICIENCY	>88%			
THD	<25%			
CURRENT CREST FACTOR	< 1.7			
EMI/RFI COMPLIANCE	-			
SOUND RATING	-			
BALLAST TYPE	RAPID START			
VOLTAGE TRANSIENTS	-			
INPUT/PROTECTION	FUSE			
OUTPUT/PROTECTION	EOL			
MIN. OPERATING TEMP	- 10 °C (14 ° F)			
MAX. CASE TEMP	75 °C (167 ° F)			
ENERGY STAR 4.0	-			
APPROVALS/CLASS	-			

MECHANICAL DATA

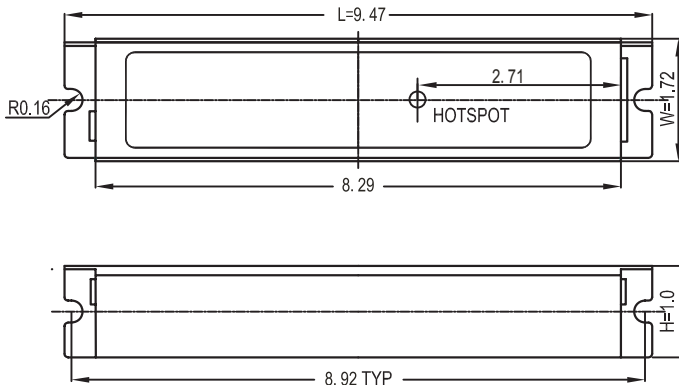

Where : L = Length, W = Width, H = Height

WIRING DIAGRAMS

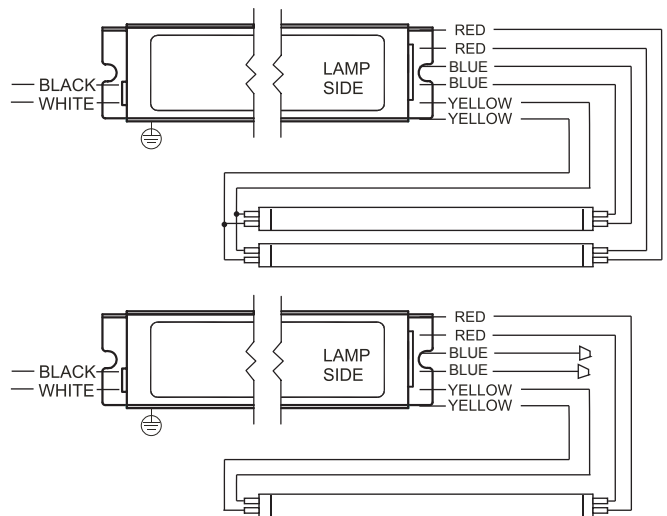

NOTE : This Ballast Must Be Grounded

Fulham Electronic Co., Ltd extends limited warranty only to the original purchaser or to the first user for the period of **3 years** from the date of manufacture when properly installed and under normal conditions of use.

DUE TO A PROGRAM OF CONTINUOUS IMPROVEMENT, FULHAM ELECTRONIC Co.,LTD RESERVES THE RIGHT TO MAKE ANY VARIATION IN DESIGN OR CONSTRUCTION TO THE EQUIPMENT DESCRIBED.

Address : 12705 South Van Ness Ave. , Hawthorne CA 90250, U. S. A Tel.:323-599-5001 Website: www.fulham.com