

Description : Series connected class II surge protective device (5KA nominal discharge current)

Intended Operation: Any Electronic control gear having input current rating upto 5A and operating voltage maximum 360Vac.

Device Rating and Specifications

RECOMMENDED MAX.OPERATING VOLTAGE	360Vac
MAXIMUM CONTINUOUS OPERATING VOLTAGE(MCOV)	440Vac
NOMINAL DISCHARGE CURRENT $I_n(A)$	5,000(15 impulses of discharge current using 8/20us current waveform)
MAXIMUM DISCHARGE CURRENT $I_{max}(A)$	10,000(single impulse of discharge current using 8/20us current waveform.)
TYPE	Test class II (IEC 61643-11)
VOLTAGE PROTECTION LEVEL(U_p)	L-N:1700, L-E: 1700, N-E: 1400
CONNECTION TYPE	SERIES
EOL INDICATION	LOAD DISCONNECTION
EOL PROTECTION	YES ; THERMAL CUTOFF
IP RATING (CONFORMING TO)	IP67
NO. OF PORTS	TWO
LOCATION CLASS	OUTDOOR
MOUNTING METHOD	FIXED
TEMPORARY OVER VOLTAGE (TOV)	440V
MAXIMUM LOAD CURRENT (I_L)	5A
HUMIDITY RANGE	5% TO 95%
OPERATING TEMPERATURE	-25 TO +85 °C
STORAGE TEMPERATURE	-25 TO +85 °C
INSULATION RESISTANCE	>1000 Megaohms
APPROVAL CLASS (CONFORMING TO)	IEC 61643-11

Note: ALL ABOVE SPECIFIED RATINGS ARE ABSOLUTE MAXIMUM RATINGS; STRESS ABOVE THESE RATINGS MAY CAUSE PERMANENT DAMAGE TO THE DEVICE.

MECHANICAL DATA

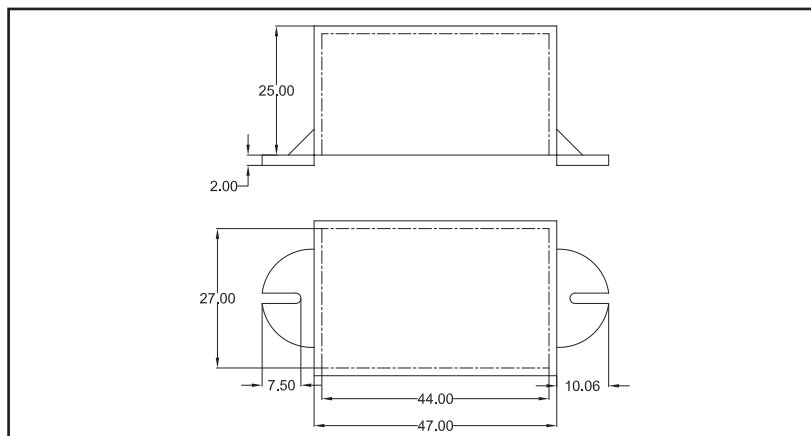

WIRING DIAGRAMS

INPUT SIDE	LENGTH	OUTPUT SIDE	LENGTH
(L) BLACK	100MM	BLACK (L)	100MM
(N) WHITE		WHITE (N)	
(E) GREEN			

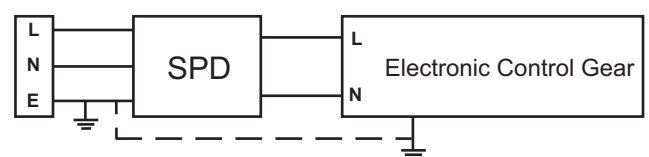

- - - If applicable

Installation Instructions: Should be used with single phase TN-S distribution systems.

Due to a program of continuous improvement, Fulham reserves the right to make modifications or variations in design or construction to the equipment described. © Fulham Company Limited, All Rights Reserved.